

---

# Note Paper Tray

---

Name: \_\_\_\_\_

**Description:**

A tray for scrap paper. Take used 8 ½" x 11" paper and cut in quarters to fill the tray. Teaches beginning sheet metal skills and plan layout. A good introduction to a variety of tools. While the project is simple it requires precision layout and bending to look good.

**Materials:**

26 ga. galvanized sheet metal  
Spray paint

**Tools:**

Combination Square  
Scratch awl/Scribe  
Sheet metal box brake  
Cornice brake  
Foot shear  
Snips  
Drill Press  
3/16" drill  
Center pinch  
Mill file

**Procedure:**

1. Optional: For practice cut out the paper exercise and fold as described below.
2. Shear metal square and to size. See plan.
3. Layout using a combination square and scribe as shown in the drawing.
4. **Have it checked by your instructor before cutting or drilling.**
5. Locate the 4 corners of the tray and mark with a center punch.
6. Drill 4 3/16" holes in the corners of the project. Clamp it securely so it cannot spin. Clean up the holes as needed (can use a 3/8" bit by hand).
7. Cut out the project with the snips (straight or duckbill work best).
8. Note the small chamfer on the sharp corners. Snip these.
9. Fold the ½" safety folds. These bends all go in the same direction and will end up on the outside of the tray. Use the brake to fold them tight.
10. Use the cornice brake to fold the sides. Opposite direction as the safety folds.
11. Use the box bake to fold the ends. Note the open end (shorter) is bent to a 45 degree angle so paper can be slid out.
12. Use a mill file to remove any burrs.
13. Wipe clean.
14. Paint with your favorite color paint.

**Cutting List:**

Quantity	Size	Material
1	8 ¼" x 7 ¾"	26 ga sheet metal

**Notes:**

---

---

---

---

---

---

---

---

---

---

---

**Photo/Drawing:**

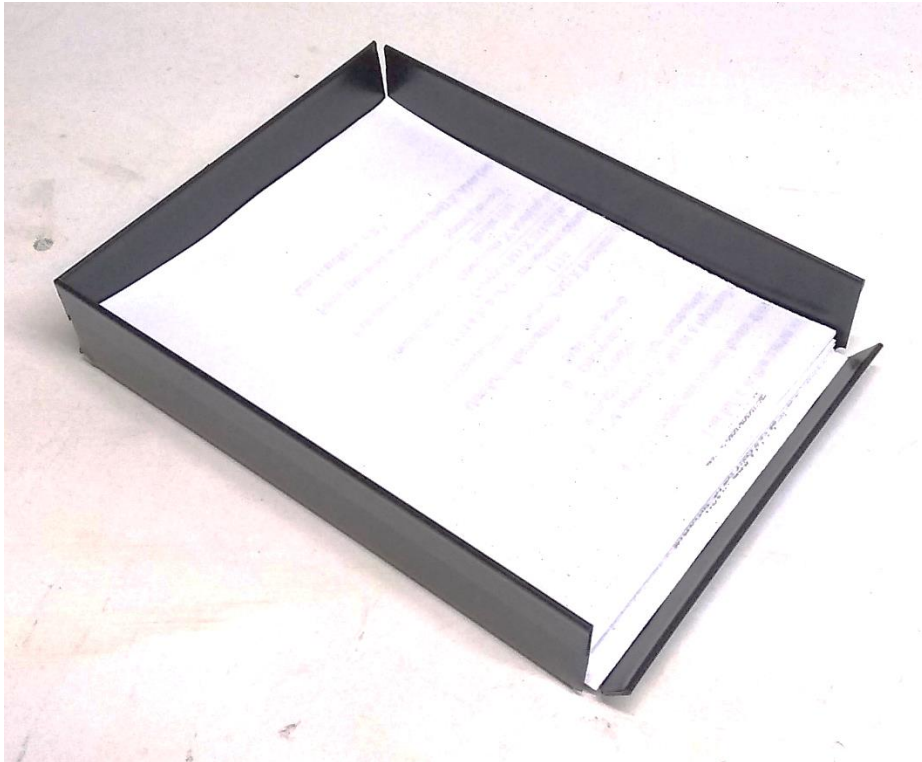

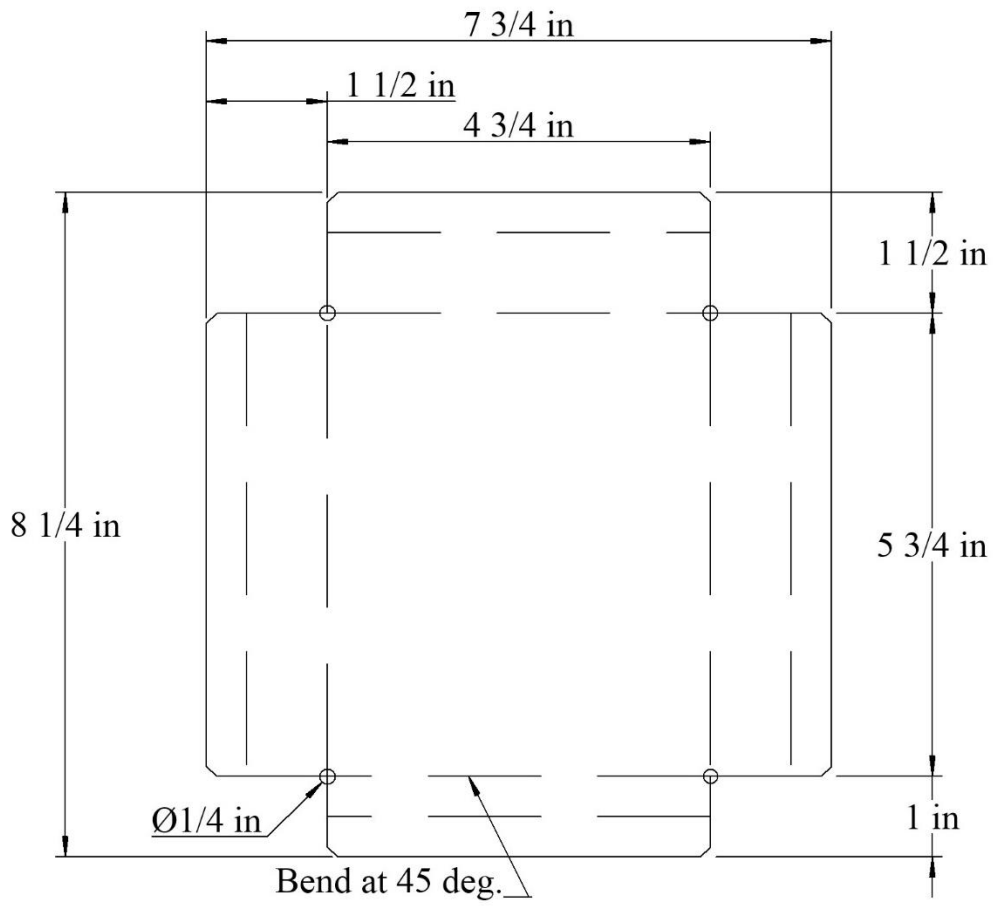

Note Paper Holder

Drawn by: M. Spiess

2/22/2020

**Exercise**

Directions: Cut out on solid lines with scissors. Fold on dashed lines.

- 1) Fold safety edges (all in the same direction).
- 2) Fold sides in the opposite direction to form the tray.

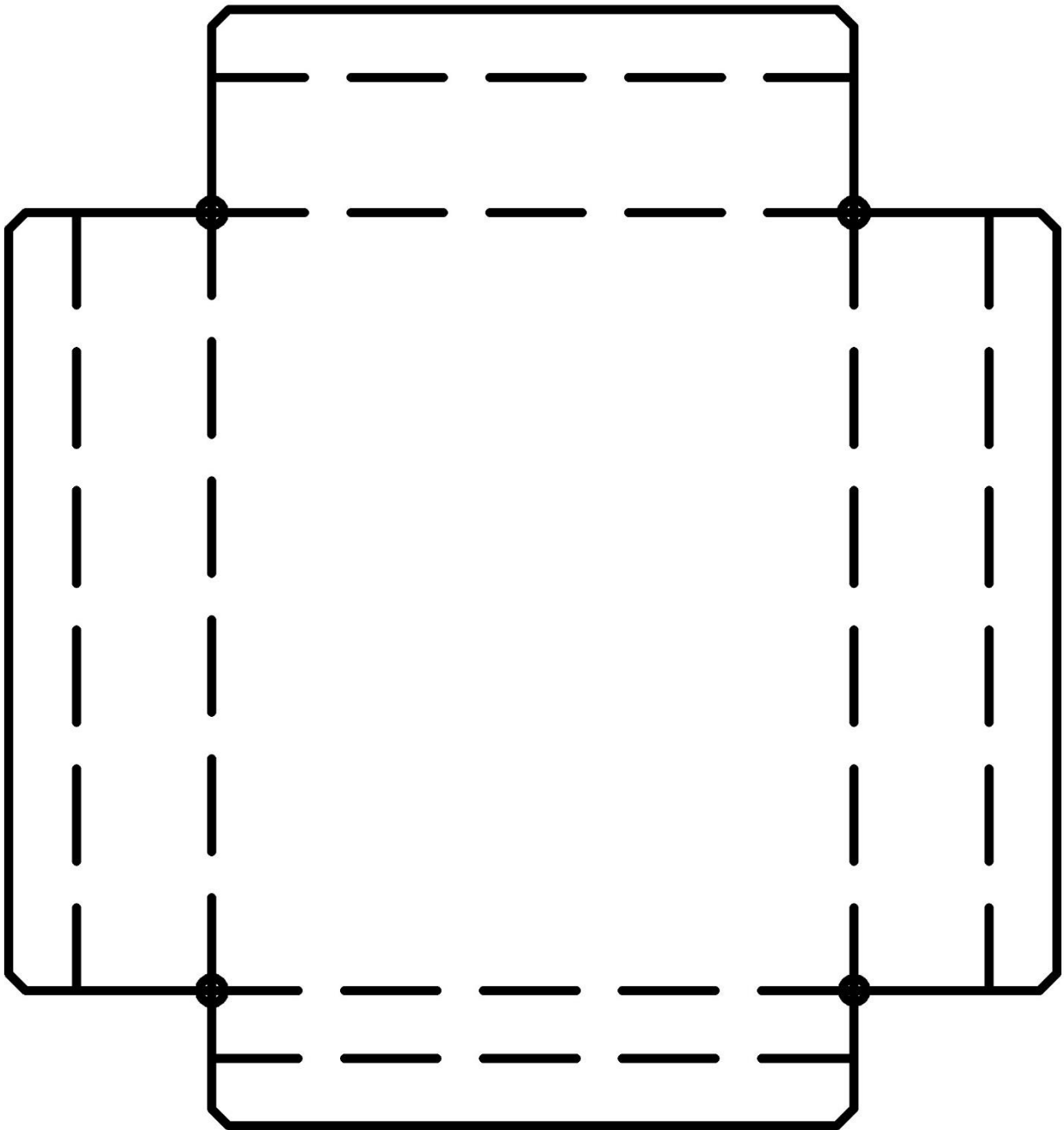

## Sheet Metal Box Worksheet

Name: \_\_\_\_\_

Date: \_\_\_\_\_

1. What are the dimensions of the finished tray supposed to be?
  
2. What tools do you use to layout the tray?
  
3. Which bends are only bent 45-degrees?
  
4. Why do we use a box brake to make the final bends?
  
5. What are the safety issues with a brake?

### Grading Rubric:

<u>CRITERIA</u>	<u>POSSIBLE</u>	<u>SCORE</u>
Proper Length	6	
Proper width	6	
Angle of bends	6	
Square	6	
Workmanship (no sharp edges, not to scuffed)	6	
Total	30	

## Sheet Metal Box Teachers Notes:

This is a good intro project. It includes basic plan reading and layout. It is harder to make than it looks. If layout and bending are sloppy it will show in the project. Cost is minimal so students can make several to get it right. Good project to take home or give as a present. Paper is simply recycled letter sized paper cut into quarters.

### Agricultural Standards Met:

- 6.0 Health and Safety. Students understand health and safety policies, procedures, regulations, and practices, including the use of equipment and handling of hazardous materials:
  - 6.1 Know policies, procedures, and regulations regarding health and safety in the workplace, including employers' and employees' responsibilities.
  - 6.2 Understand critical elements of health and safety practices related to storing, cleaning, and maintaining tools, equipment, and supplies.
  - 6.4 Maintain safe and healthful working conditions.
  - 6.5 Use tools and machines safely and appropriately.
  - 6.6 Know how to both prevent and respond to accidents in the agricultural industry.
- B1.0 Students understand personal and group safety:
  - B1.1 Practice the rules for personal and group safety while working in an agricultural mechanics environment.
  - B1.2 Know the relationship between accepted shop management procedures and a safe working environment.
- B5.0 Students understand agricultural cold metal processes.
  - B5.3 Know layout skills
  - B5.4 Know basic cold metal processes (e.g., shearing, cutting, drilling, threading, bending.)

### Objectives:

By properly completing this project, students will be able to:

- Read a plan and layout dimensions.
- Demonstrate construction techniques for sheet metal including shearing, bending, drilling.

### Alternative Tools/Methods/Materials:

- Tabs could be added to the sides and then spot welded. This added an additional skill to the project.
- All bends can be done on a small bench box brake,

**Safety Review:**

- Working sheet metal (sharp)
- Sheet metal brake
- Drill press
- Spray paint

**Project Time:**

Demonstration:	30 minutes
Build:	3 hours

**Demonstration Notes**

1. Use the exercise and scissors to have the students practice bends. This also shows how the 2D drawing becomes a 3D project.
2. Entire project can be make from scraps.
3. Shearing the initial rectangle square is critical.
4. Demonstrate the use of a combination square for layout. This is a critical layout skill. See: <http://www.agedweb.org/TeacherResources/Use%20of%20the%20Combination%20Square%20for%20Layout.pdf> for a tutorial.
5. Demonstate drilling sheet metal. Caution: Eben with a small bit it can spin. Use a piect of wood for backing and clamp.
6. Demonstrate how to cut out the corners with snips.
7. Review the order of the bends.
8. Demonstrate using the cornice brake to make the safety folds (crush tight so they are flat).
9. Fold the sides in the cornice brake.
10. Demonstrate using the box brake to fold the ends.
11. Demonstrate how to clean up the project with the mill file. No sharp edges!
12. Show how safely paint (ventilation) and move the spray can to avoid drips.

**Bill of Materials:**

Use scraps.

Plan by: M. Spiess